

BLDC3657

Brushless Dc Motor

POINT1 : Gear Motor、Pump、Electric Fan

用途：齒輪箱、泵浦、風扇

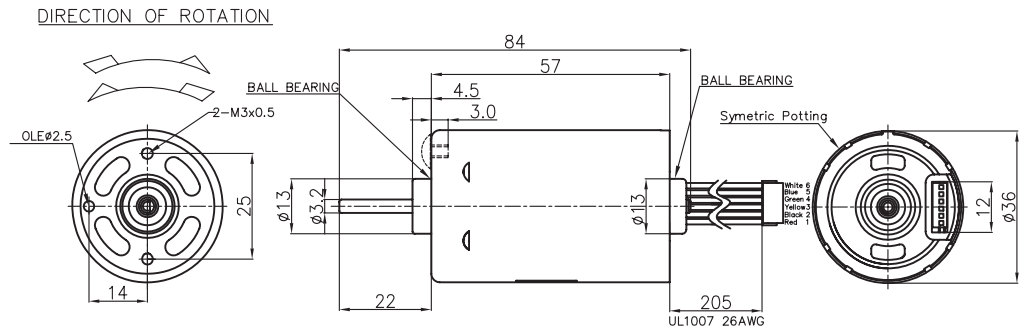

WEIGHT : 200g(APPROX)

Motor With Hall	Definition of the wire	+DC: 24V	—	direction	Speed control	Speed signal	ON/OFF
	Color of the wire	Red	Black	Yellow	Green	Blue	White
	Wire gauge (silicon coat)	AWG26#	AWG26#	AWG26#	AWG26#	AWG26#	AWG26#

MODEL	VOLTAGE		NO LOAD		AT MAXIMUM EFFICIENCY					STALL			
	OPERATING RANGE	NOMINAL	SPEED	CURRENT	SPEED	CURRENT	TORQUE	OUTPUT	EFF	CURRENT	TORQUE		
			rpm	A	rpm	A	g-cm	mN-m	W	%	A	g-cm	mN-m
BLDC3657B1HY-24V-6K-25W	21V-27V	24V constant	6050	0.3	5020	1.5	488	47.9	25	73	7.9	2900	284

馬達的出軸長度及性能參數，EMC 對策可依客人要求做調整，詳情可詢問相關業務人員。
Please inquire your sales representative for output, performance and EMC solution.

