

# BL2838

Brushless Dc Motor

Application : Robot Vacuum

用途：智能吸塵機器人

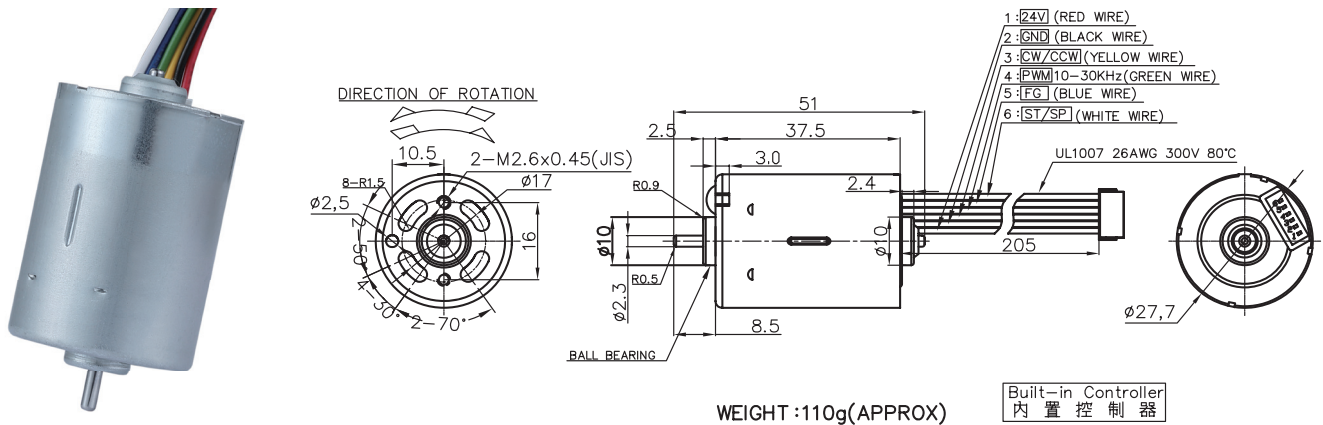

MODEL	VOLTAGE		NO LOAD		AT MAXIMUM EFFICIENCY						STALL		
	OPERATING RANGE	NOMINAL	SPEED rpm	CURRENT A	SPEED rpm	CURRENT A	TORQUE g-cm	TORQUE mN-m	OUTPUT W	EFF %	CURRENT A	TORQUE g-cm	TORQUE mN-m
BL2838B-12V2.9K1.4W-B0X0N	9.0-30.0	12.0V CONSTANT	2900	0.67	2248	0.28	62.55	6.13	1.44	55	0.82	267.59	26.23
BL2838B-12V12.7K15W-B1X0N	9.0-30.0	12.0V CONSTANT	12700	0.31	10730	1.79	140.30	13.75	15.46	76	8.61	803.31	78.76
BL2838B-24V6.0K4W-C1Y1P	9.0-30.0	24.0V CONSTANT	6000	0.05	5139	0.28	82.83	8.12	4.37	70	1.45	541.46	53.08
BL2838B-12V10K10W-C1Y1P	9.0-30.0	12.0V CONSTANT	10380	0.21	8834	1.21	117.20	11.49	10.63	75	6.63	742.35	72.78

馬達的出軸長度及性能參數，EMC 對策可依客人要求做調整，詳情可詢問相關業務人員。  
Please inquire your sales representative for output, performance and EMC solution.

